

DS4-140-010-H
DS4-140-020-H
DS4-140-030-H
DS4-340-2K2-M(R)
DS4-340-7K5-MX(R)
DS4-340-11K-MX(R)

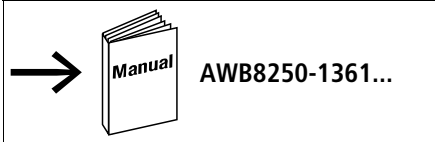

→ Das Gerät ist für den industriellen Einsatz geeignet (→ EN 55011/22 Klasse A).
The device is suitable for use in industrial environments (→ EN 55011/22 Class A).
L'appareil a été conçu pour l'emploi en milieu industriel (→ EN 55011/22 classe A).
L'apparecchio è adatto per uso in ambienti industriali (→ EN 55011/22 Classe A).
El aparato es adecuado para uso en ambiente industrial (→ EN 55011/22 clase A).
Прибор пригоден для промышленной эксплуатации (→ EN 55011/22 Класс А).
此设备适合于工业用途
(--> EN 55011/22 等级 A)



Lebensgefahr durch elektrischen Strom!
Nur Elektrofachkräfte und elektrotechnisch unterwiesene Personen dürfen die im Folgenden beschriebenen Arbeiten ausführen.

Electric current! Danger to life!

Only skilled or instructed persons may carry out the following operations.

Tension électrique dangereuse !

Seules les personnes qualifiées et averties doivent exécuter les travaux ci-après.

Tensione elettrica: Pericolo di morte!

Solo persone abilitate e qualificate possono eseguire le operazioni di seguito riportate.

¡Corriente eléctrica! ¡Peligro de muerte!

El trabajo a continuación descrito debe ser realizado por personas cualificadas y advertidas.

Электрический ток! Опасно для жизни!

Только специалисты или проинструктированные лица могут выполнять следующие операции.

触电危险!

只允许专业人员和受过专业训练的人员进行下列工作。

DS4-340-2K2-M(R)
DS4-340-7K5-MX(R)
DS4-340-11K-MX(R)

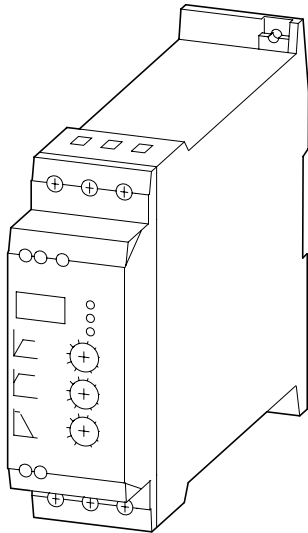

DS4-140-010-H
DS4-140-020-H
DS4-140-030-H

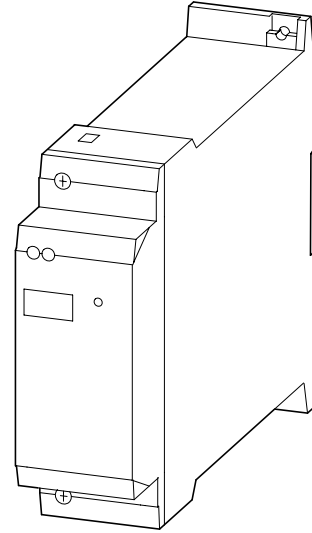

Abmessungen – Dimensions – Dimensioni – Dimensiones – Размеры и веса – 尺寸 [mm]

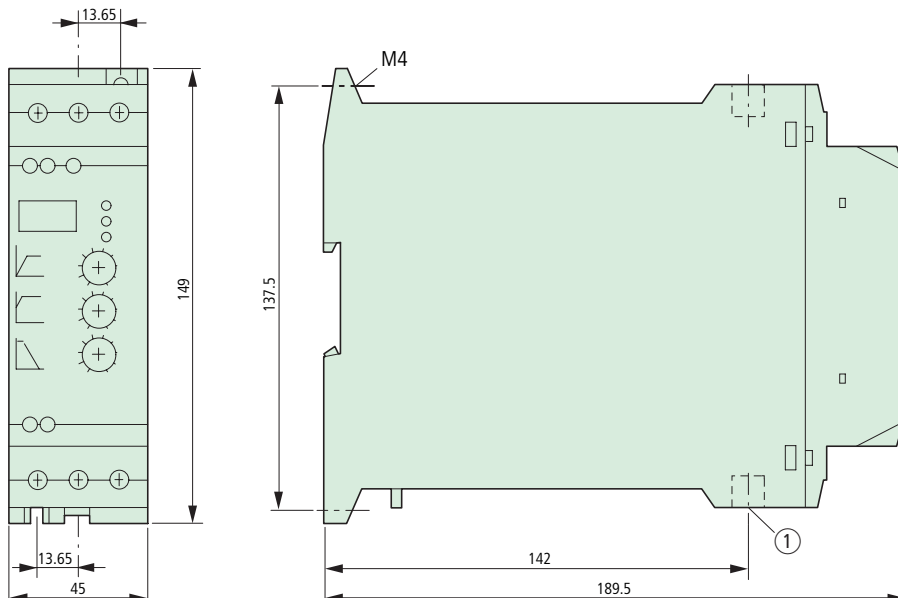

① 1L1, 3L2, 5L3,
2T1, 4T2, 6T3

Einbaulage – Mounting position – Position de montage –
 Posizione di montaggio – Posición de montaje –
 Положение установки – 安装位置

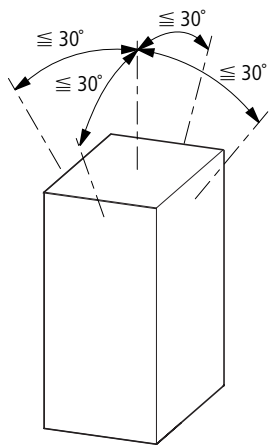

Einbaumaße – Fitting dimensions – Dimensions de montage –
 Dimensioni di montaggio – Dimensiones de montaje –
 монтажные размеры – 安装尺寸

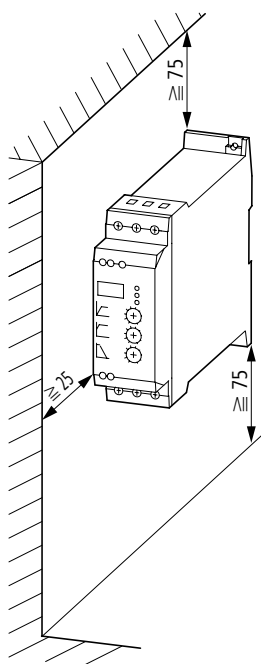

Montage – Mounting – Montaggio – Montaje – Монтаж – 安装

A

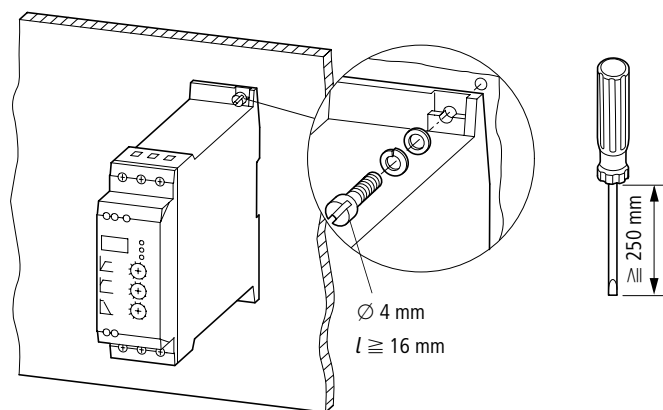

B

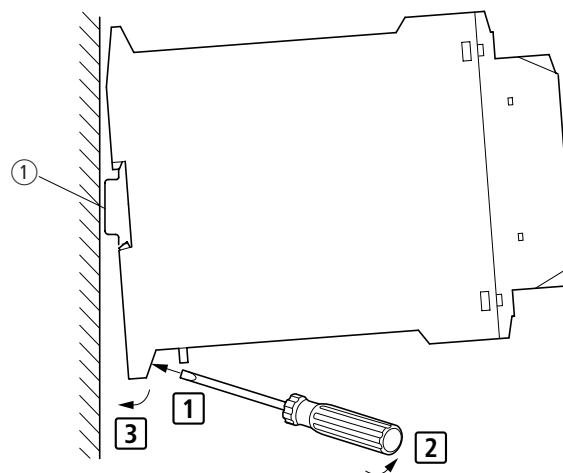

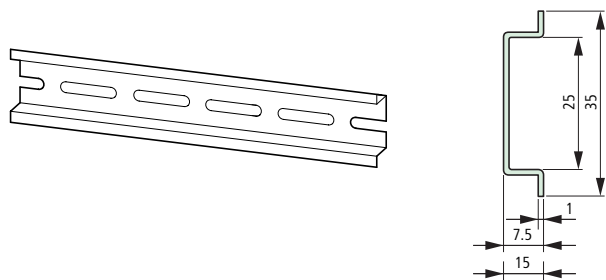

- ① Montageschiene DIN EN 50022-35
- ① Top-hat rail DIN EN 50022-35
- ① Profilé-support DIN EN 50022-35
- ① Guida DIN EN 50022-35
- ① Guía simétrica DIN EN 50022-35
- ① Монтажная шина EN 50022-35
- ① 安装轨 EN 50022-35



09/05 AWA8250-1944



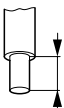
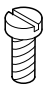
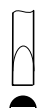

Leitungsquerschnitt – Cable cross-section – Sections raccordable – Sezione del cavo – Sección de conductor – Поперечное сечение провода – 导线横截面

Steuerleitungen – Control cables – Conducteurs de commande – Cavi comandi – Conductores de mando – Линии управления – 控制线

		A1, A2 FWD, 0, REV 13, 14			
					
		mm	Nm	mm	mm
1 ×	0.75 – 2.5	18 – 12	6	0.8	0.5 × 3.5
2 ×	0.75 – 1.5	–	11	0.8	0.5 × 3.5

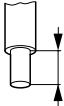
→ Bei Mehrleiteranschluss darf maximal ein DIN-Normgrößen-Sprung zwischen den verwendeten Leitern liegen.
Where several conductors are to be connected, the difference between the wires/cables used must not exceed one DIN Standard size level.
En cas de raccordement de plusieurs conducteurs, il faut 1 écartement normalisé max. entre les conducteurs.
In caso di collegamento a più conduttori, è ammesso al massimo un salto di grandezze DIN standard fra i conduttori utilizzati.
En caso de conexión de múltiples conductores puede haber como máximo un salto de magnitud normalizada DIN entre los conductores utilizados.
При многопроводном присоединении скачок между применяемыми проводами должен составлять максимум одну номинальную величину по ДИНУ.
在多个导体连接时在所用导体间最多允许有一个 DIN 标准尺寸的差别。

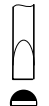
Leistungsleitungen – Power cables – Conducteurs de puissance – Cavi di potenza – Conductores de potencia – Силовые линии – 负载线

		1L1, 3L2, 5L3, 2T1, 4T2, 6T3				
						
		mm	Nm	mm	mm	
1 ×	1.5 – 6	16 – 8	10	1.7	1 × 6	PZ 2
2 ×	1.5 – 4	–	10	1.7	1 × 6	PZ 2

→ **Attention:**
For UL applications use with solid conductors only.
Use 60/75 °C rated copper wire.

09/05 AWA8250-1944

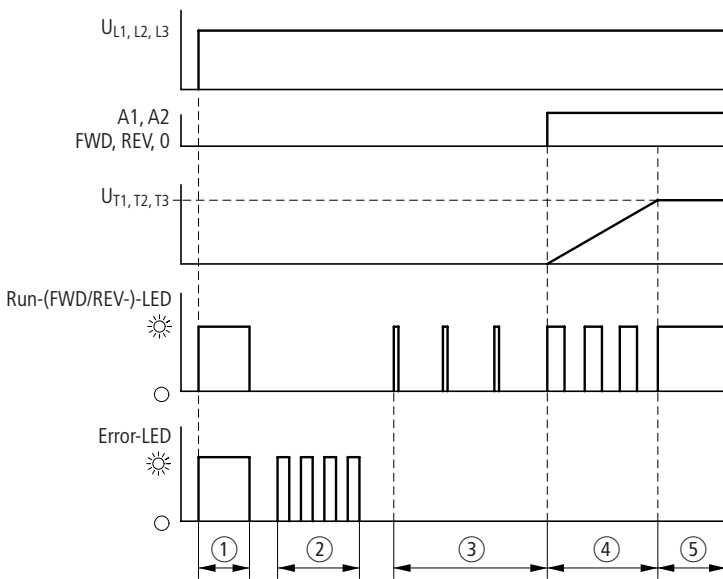

Run-(FWD/REV)-LED grün – Run (FWD/REV)-LED green – DEL Run (FWD/REV) vert – LED Run (FWD/REV) verde – LED Run (FWD/REV) verde – Зануок (FWD/REV-) СИД зеленый – 运行 (前进/后退) LED 灯绿色

Fehler LED rot – Error LED red – DEL erreur rouge – LED errore rosso – LED error rojo – Ошибка СИД красный – 故障 LED 灯红色

- ① Initialisierung – Initialisation – Initialisation – Inizializzazione – Inicialización – Инициализация – 初始
- ② Fehler – Fault – Défait – Errore – Avería – Повреждение – 故障
- ③ Betriebsbereit – Ready for operation – Prêt à fonctionner – Pronto al funzionamento – En condiciones para funcionamiento – Готов к работе – 准备就绪
- ④ in Rampe – in ramp – en rampe – in rampa – en rampa – в рампе – 斜坡中
- ⑤ Rampenende erreicht – Top of ramp – Fin de rampe atteinte – Fine rampa – Fin de rampa – Вершина рампы – 斜坡顶端

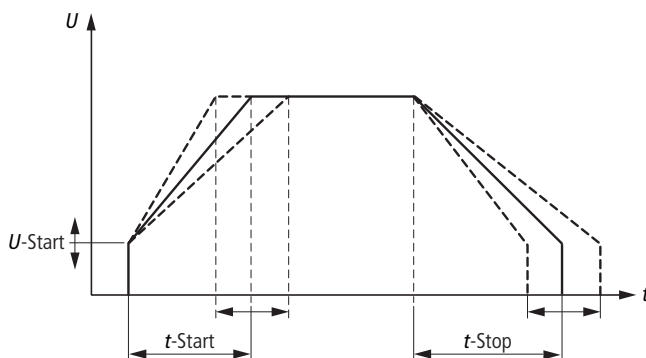
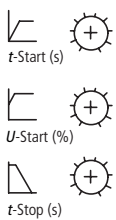

t-Start, t-Stop → 10 s

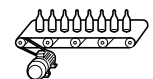

→ 1 s



U-Start → 30 %

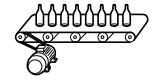
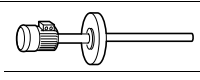

→ 100 %

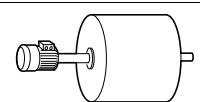

Externe Zusatzkomponenten – External add-on components – Éléments complémentaires externes – Componente aggiuntivo esterno – Componentes adicionales externos – Внешние дополнительные компоненты – 外部附加组件

Softstarterfunktion – Soft starter function – Fonction démarreur progressif – Funzione softstarter – Función de arranque suave –

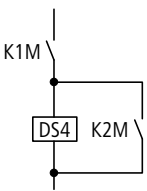
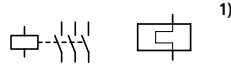

Плавная стартерная функция – 软起动器功能

DS4-340-...

	P_M	I_e	I_{eff}	Class 1	Class 2	K1M ²⁾		
	400 V 460 V				$I_q \rightarrow PK(Z)M/PKZ$	$I_q \leq 100 \text{ kA}$		¹⁾
	[kW]	[HP]	[A]	[A]	①	②		
X = 3 × I_e, T_x = 5 s, S = 10/h, ED = 99 %								
DS4-340-2K2-M(R)	2,2	3	5	7	PKM0-6,3 (+ CL-PKZ0)	50.140.06-50A	DILM7	ZB12-6
DS4-340-7K5-MX(R)	7,5	10	15,2	18	PKM0-16 (+ CL-PKZ0)	50.140.06-63A	DILM17	ZB32-16 (+ ZB32-XEZ)
DS4-340-11K-MX(R)	11	15	21,7	27	PKM0-25 (+ CL-PKZ0)	50.140.06-80A	DILM25	ZB32-24 (+ ZB32-XEZ)
X = 6 × I_e, T_x = 5 s, S = 20/h, ED = 99 %								
DS4-340-2K2-M(R)	2,2	3	5	9	PKM0-10 (+ CL-PKZ0)	50.140.06-50A	DILM9	ZEV + ZEV-XSW-25
X = 6 × I_e, T_x = 0,5 s, S = 600/h, ED = 99 %								
DS4-340-2K2-M(R)	2,2	3	5	12	PKM0-10 (+ CL-PKZ0)	50.140.06-50A	DILM12	ZEV + ZEV-XSW-25

Halbleiterschützfunktion – Semiconductor contactor function – Fonction contacteur à semi-conducteurs – Protezione del semiconduttore – Función de contactor semiconductor – Полупроводниковая контакторная функция – 半导体接触器功能

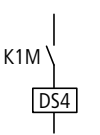
DS4-140-...

	I_e	Class 1	400 V	500 V	Class 2	K1M ²⁾
	[A]	230 V $I_q \leq 15 \text{ kA}$	$I_q \leq 15 \text{ kA}$	$I_q \leq 6(10) \text{ kA}$	$I_q \leq 100 \text{ kA}$	
		①	①	①	②	
DS4-140-010-H	10	FAZ-B10	2 * FAZ-B10	PKM0-10 (+ CL-PKZ0) + ZB12-10	50.179.06-16A	DILM7
DS4-140-020-H	20	FAZ-B20	2 * FAZ-B20	PKM0-20 (+ CL-PKZ0) + ZB32-24 (+ ZB32-XEZ)	50.124.06-32A	DILM17
DS4-140-030-H	30	FAZ-B32	2 * FAZ-B32	PKZM0-32 (+ CL-PKZ0) + ZB32-32 (+ ZB32-XEZ)	50.140.06-50A	DILM25

Hinweise – Notes – Remarques – Note – Notas – Указание – 提示

- 1) Alternativ kann auch ein Motorschutzschalter mit internem Überlastschutz verwendet werden (z. B. PKZM0, NZM ohne den Zusatz „-OBI“)
 - 1) A motor-protective switch with internal overload protection may be used as an alternative (e. g. PKZM0, NZM without Type suffix "-OBI")
 - 1) Possibilité d'utilisation au choix d'un disjoncteur-moteur avec protection contre les surcharges intégrée (p. ex. PKZM0, NZM dont la référence ne se termine pas par « -OBI »)
 - 1) In alternativa può anche essere utilizzato un interruttore protettore con protezione termica (relè) incorporata (ad esempio PKZ0, NZM senza il suffisso -OBI)
 - 1) Alternativamente puede también utilizarse un interruptor protector de motor con protección de sobrecargas (p. ej. PKZM0, NZM sin el sufijo "-OBI")
 - 1) В качестве альтернативы можно применять защитный автомат двигателя с внутренним устройством защиты от перегрузок (напр., PKZM0, NZM без добавки „-OBI“)
 - 1) 也可选择使用带内部过载保护的电机保护开关 (例如PKZM0、NZM 不附加 "-OBI")
- 2) optional – en option – opzionale – opcional – по выбору – 选装
- Class 1 = ①
Class 2 = ① + ②



Achtung!

Im Geltungsbereich der EG-Richtlinien dürfen die Softstarter der Reihe DS4 und deren Zubehör nur dann in Betrieb genommen werden, wenn festgestellt wird, dass die Maschine die Schutzanforderungen der Maschinenrichtlinie 89/392/EWG erfüllt.

Attention!

Within the scope of the EU Directives, the soft starters of series DS4 and their accessories may be commissioned only provided it is established that the machine fulfils the protective requirements of Machine Directive 89/392/EWG.

Attention !

En application des directives européennes, les démarreurs progressifs de la gamme DS4 et leurs accessoires ne doivent être mis en service que s'il a été vérifié que la machine répond bien aux exigences de la directive machines 89/392/EWG.

Attenzione!

Nel campo di validità delle direttive CEE i softstarter della serie DS4 e i loro accessori possono essere messi in esercizio solamente se è verificato che la macchina soddisfa i requisiti di sicurezza delle direttive macchine 89/392/CEE.

¡Atención!

En el campo de aplicación de la normativa CE, los arrancadores suaves de la serie DS4 y sus correspondientes accesorios sólo deberán ponerse en marcha cuando se asegure que la máquina cumple con las exigencias de seguridad de la normativa de máquinas 89/392/CE.

Внимание!

На территории действия Предписаний ЕС плавный стартер ряда DS4 и его принадлежности можно вводить в эксплуатацию только в том случае, если будет установлено, что машина выполняет требования по защите согласно Предписанию для машин 89/392/ЕЭС.

注意!

在 EG 准则的适用范围中, 只有当已确定机器设备满足了机器准则 89/392/EWG 的保护要求时, DS4 系列软起动器及其附件才能投入适用。

Standardanschluss – Standard connection – Raccordement standard – Collegamento standard – Conexión estándar –
Стандартное присоединение – 标准接头

DS4-140

1 ~ 230 V

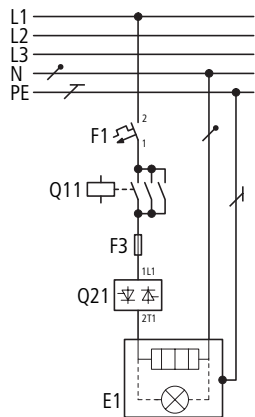

2 ~ 400 V

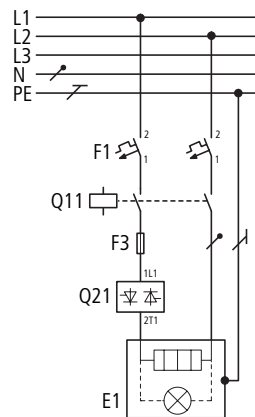

2 ~ 500 V

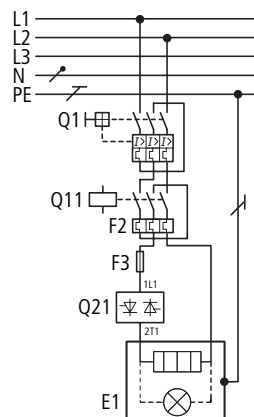

Ansteuerung – Control – Commande –
Comando – Control – Управление –
控制装置

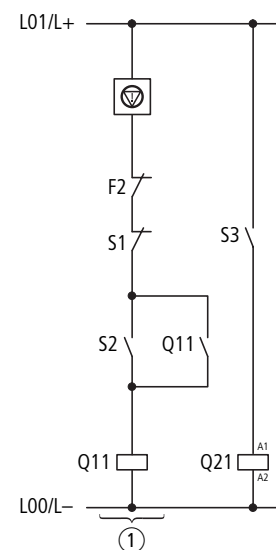

DS4-340-M

Halbleiterschütz – Semiconductor contactor – Contacteur à semi-conducteurs – Contattore a semiconduttori – Contactor semiconductor –
Полупроводниковый пускатель – 半导体接触器

09/05 AWA8250-1944

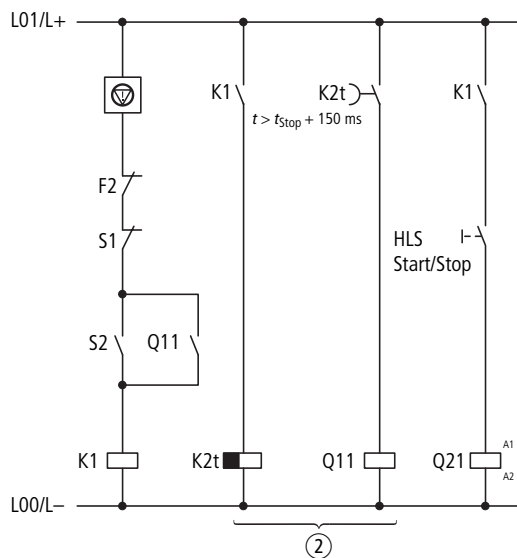
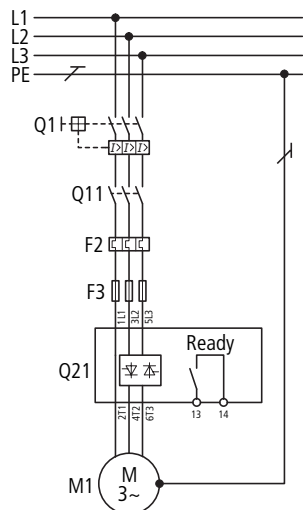

DS4-340-M(X)

Softstarter – Soft starter – Démarreur progressif – Arrancador suave – Пусковое средство программы – 软起动器

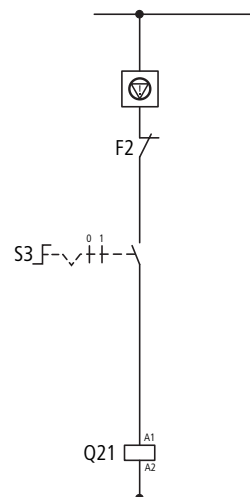
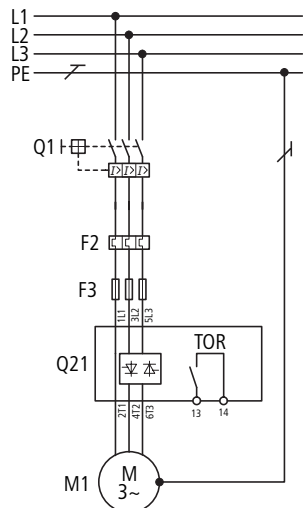

⊕ NOT-AUS
EMERGENCY-STOP
ARRET D'URGENCE
ARRESTO D'EMERGENZA
PARADA DE EMERGENCIA
Аварийное выключение
紧急关闭

0: Soft-Stop
Aus – Off – Arrêt – Paro – Выкл – 输出
1: Soft-Start
Start – Démarrage – Arranque –
Старт – 起动

DS4-340-M(X)

Softstarter mit Netzschütz – Soft starter with mains contactor – Démarreur progressif avec contacteur réseau – Softstarter con contattore di rete – Arrancador suave con contactor red – Пусковое средство программы с сетевым контактором – 软起动器及网路接触器

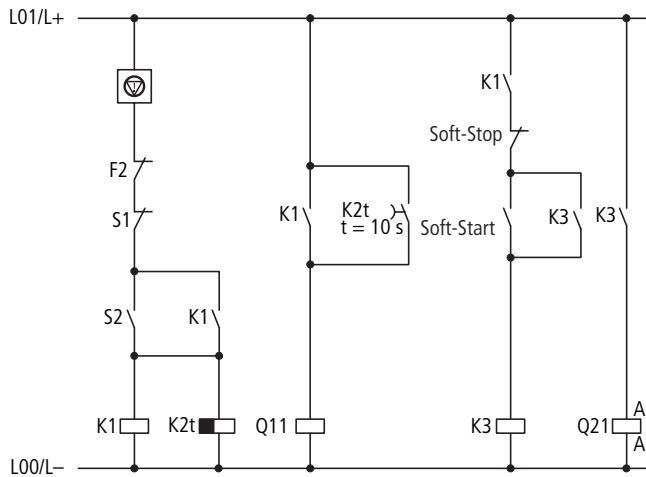
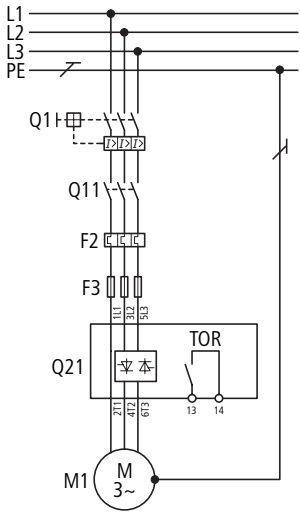

DS4-340-M(X)R

Wende-Softstarter – Reversing soft starter – Démarreur progressif inverseur – Softstarter con inversione di marcia – Arrancador suave inversor – Реверсивный плавный стартер – 换向软起动器

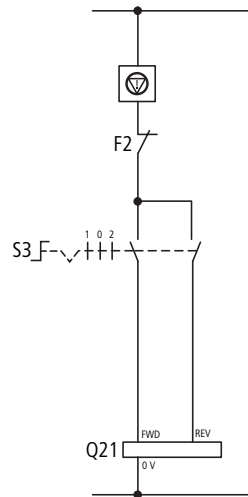
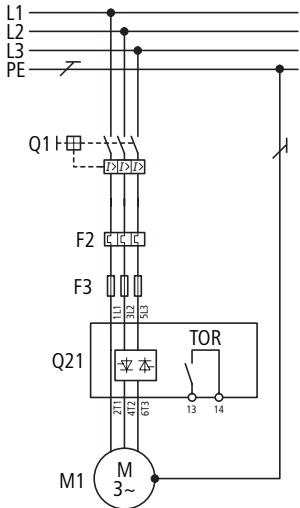

NOT-AUS
 EMERGENCY-STOP
 ARRET D'URGENCE
 ARRESTO D'EMERGENZA
 PARADA DE EMERGENCIA
 Аварийное выключение
 紧急关闭

0: Soft-Stop
 Aus – Off – Arrêt – Paro – Выкл – 输出
 1: FWD
 2: REV

09/05 AWA8250-1944

DS4-340-M(X)R

Wende-Softstarter mit Netzschütz – Reversing soft starter with mains contactor – Démarreur progressif inverseur avec contacteur réseau – Softstarter con inversione di marcia e contattore di linea – Arrancador suave inversor con contactor de red – Реверсивный плавный стартер с сетевым контактором – 换向软起动器及网路接触器

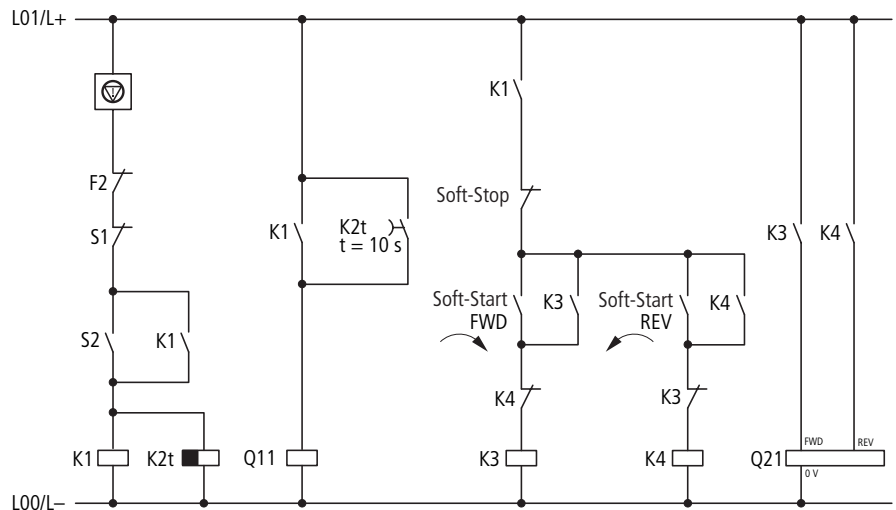
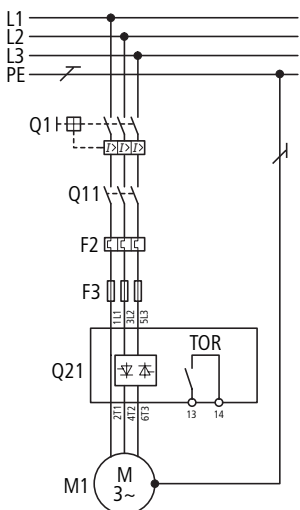

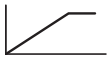

Soft-Start: Start – Démarrage – Arranque – Старт – 启动

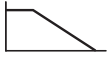

Soft-Stop: Aus – Off – Arrêt – Paro – Выкл – 输出



FWD Rechtsdrehfeld – Clockwise rotating field – Champ tournant à droite – Campo di rotazione oraria – Campo giratorio a la derecha – Прямое направление вращения – 右旋区



REV Linksdrehfeld – Anti-clockwise rotating field – Champ tournant à gauche – Campo di rotazione antioraria – Campo giratorio a la izquierda – Реверсивное направление вращения – 左旋区

F1, Q1 = Leitungsschutz
 Q11 = Netzschütz (optional)
 Q22 = Bypass-Schütz (optional)
 F2 = Überlastrelais (optional)
 F3 = Halbleitersicherung für Zuordnungsart 2, zusätzlich zu F1, Q1
 Q21 = Halbleiterschütz/Softstarter
 E1 = Last (Heizung, Lampe)
 M1 = Motor
 S1 = Aus
 S2 = Ein
 S3 = Start/Stopp
 ① = Ansteuerzweig mit Q11 (optional)
 ② = Ansteuerzweig mit Q11/K2 (optional)
 Ⓢ = NOT-AUS

F1, Q1 = Protezione di linea
 Q11 = Contattore di rete (opzionale)
 Q22 = Contattore di bypass (opzionale)
 F2 = Relè termico (opzionale)
 F3 = Per avere la protezione del semiconduttore in coordinamento di tipo 2, è necessario un fusibile in aggiunta a F1, Q1
 Q21 = Contactor semiconductor/softstarter
 E1 = Carico (riscaldamento, lampada)
 M1 = Motore
 S1 = Off
 S2 = On
 S3 = Start/Stop
 ① = Il contattore di comando con Q11 (opzionale)
 ② = Il contattore di comando con Q11/K2 (opzionale)
 Ⓢ = ARRESTO D'EMERGENZA

F1, Q1 = 线路保护
 Q11 = 网路接触器 (选装)
 Q22 = 旁路继电器 (选装)
 F2 = 过载继电器 (选装)
 F3 = 用于分配类型 2 的半导体保险丝, 附加至 F1、Q1
 Q21 = 半导体接触器
 E1 = 负荷 (加热装置、灯)
 M1 = 电动机
 S1 = 输出
 S2 = 输入
 S3 = 启动/停止
 ① = 带 Q11 的控制支路 (选装)
 ② = 带 Q11/K2 的控制支路 (选装)
 Ⓢ = 紧急关闭

09/05 AWA8250-1944

F1, Q1 = Cable protection
 Q11 = Mains contactor (optional)
 Q22 = Bypass contactor (optional)
 F2 = Overload relay (optional)
 F3 = Semiconductor fuse for Type "2" coordination, in addition to F1, Q1
 Q21 = Semiconductor contactor/Soft starter
 E1 = Load (heating, lamp)
 M1 = Motor
 S1 = Off
 S2 = On
 S3 = Start/Stop
 ① = Actuating branch circuit with Q11 (optional)
 ② = Actuating branch circuit with Q11/K2 (optional)
 Ⓢ = EMERGENCY-STOP

F1, Q1 = Protección de cable
 Q11 = Contactor red (opcional)
 Q22 = Protección bypass (opcional)
 F2 = Relé de sobrecarga (opcional)
 F3 = Fusible semiconductor para tipo de coordinación 2, adicionalmente a F1, Q1
 Q21 = Contattore a semiconduttori/Arrancador suave
 E1 = Carga (calefacción, lámpara)
 M1 = Motor
 S1 = Paro
 S2 = Marcha
 S3 = Arranque/Parada
 ① = Ramal de direccionamiento con Q11 (opcional)
 ② = Ramal de direccionamiento con Q11/K2 (opcional)
 Ⓢ = PARADA DE EMERGENCIA

F1, Q1 = Protection de câbles
 Q11 = Contacteur réseau (en option)
 Q22 = Contacteur de bypass (en option)
 F2 = Relais thermique (en option)
 F3 = Fusible pour semi-conducteurs pour coordination de type 2, additionnel à F1, Q1
 Q21 = Contacteur à semi-conducteurs/Démarrage progressif
 E1 = Charge (chauffage, lampe)
 M1 = Moteur
 S1 = Arrêt
 S2 = Marche
 S3 = Démarrage/Arrêt
 ① = Commande avec Q11 (en option)
 ② = Commande avec Q11/K2 (en option)
 Ⓢ = ARRET D'URGENCE

F1, Q1 = Защита линий
 Q11 = Сетевой контактор (по выбору)
 Q22 = Байпасный контактор (по выбору)
 F2 = Реле защиты от перегрузки (по выбору)
 F3 = Полупроводниковый предохранитель для вида соединения 2, дополнительно к F1, Q1
 Q21 = Полупроводниковый пускатель / Пусковое средство программы
 E1 = Нагрузка (нагревательный элемент, лампа)
 M1 = Двигатель
 S1 = Выкл
 S2 = Вкл
 S3 = Старт/Стоп
 ① = Ветвь управления с Q11 (по выбору)
 ② = Ветвь управления с Q11/K2 (по выбору)
 Ⓢ = Аварийное выключение